

Eastwood[®]

DO THE JOB RIGHT.[®]

Item #10680

INFRARED LIGHT CURE SYSTEM INSTRUCTIONS



Your **INFRARED LIGHT** will cure parts too large to fit in your oven, or take the place of an oven.

For best results, follow the enclosed directions. The medium wave-length (2.35 micron) light heats the surface quicker than an enclosed oven, so accurate temperature control, light positioning, and movement are crucial to properly cure the powder without burning the coating. Small items will cure in about 6-15 minutes while large parts may require 2-6 hours (total elapsed time).

CONTENTS

- (1) Light Housing with Wire Guard Installed
- (3) Elements
- (1) Infrared Light Stand with Instructions

SAFETY INFORMATION

The following explanations are displayed in this manual, on the labeling, and on all other information provided with this product:

DANGER

DANGER indicates a hazardous situation which, if not avoided, will result in death or serious injury.

WARNING

WARNING indicates a hazardous situation which, if not avoided, could result in death or serious injury.

CAUTION

CAUTION used with the safety alert symbol, indicates a hazardous situation which, if not avoided, could result in minor or moderate injury.

NOTICE

NOTICE is used to address practices not related to personal injury.

SAFETY INFORMATION

⚠ DANGER

THIS LAMP EMITS INFRARED RADIATION AT HIGH TEMPERATURES! EXPOSURE TO THIS RADIATION WILL QUICKLY CAUSE SEVERE SKIN BURNS AND IGNITE CLOTHING! USE EXTREME CAUTION!



READ INSTRUCTIONS

- Thoroughly read and understand this manual before using.
- Save for future reference.



⚠ DANGER

- **DO NOT** touch the elements when they're on or before they are fully cooled.
- Unplug Lamp before cleaning or changing Elements.
- Only clean the elements with clean rags and alcohol when they are cool and the light is unplugged.
- **DO NOT** use in damp or wet locations.
- Always use with a grounded outlet rated for 30A at 220V.



⚠ WARNING FLAMMABILITY AND EXPLOSION HAZARD!

- **DO NOT** operate within 25' of flammable materials or vapors. Infrared light can heat objects up to 25' away and cause combustion.
- **NEVER** block front of light unit or cover any portion of the unit.
- **DO NOT** allow light to focus on people or combustible materials.
- **NEVER** leave light unattended while in use.
- To reduce risk of explosion, **DO NOT** turn on light within 10 feet of powder application operation.
- **DO NOT** direct at reflective surfaces.



⚠ CAUTION

- Handle light carefully to avoid breaking the elements.
- Wear eye protection and gloves when changing elements.
- **DO NOT** operate light while it is sitting on the floor, table, or other uneven surface. Only operate on a suitable stand.
- **NEVER** allow the light to be near the spraying of powder. The powder will stick to the elements, adversely affecting the curing performance.

ATTACHING LIGHT TO THE STAND

Assemble the Light Stand according to the instructions provided with the stand. Remove packing foam from behind elements and tape securing wire guard to housing.

⚠ CAUTION

Heating Elements are fragile – handle with care!

Attach Arm Assembly to the light utilizing the supplied hardware. Slide the Arm Assembly over upright on stand and tighten lock handle securely at desired height. The angle of the light can be easily adjusted by loosening the knob located on the back of the light housing. Once the light is positioned at the desired angle or orientation, tighten the knob securely (**FIGS A, B**).



SUPPORTING PARTS

One of the best methods for applying powder and for using the light for curing is by fastening a strong wire “clothesline” in your ventilated shop or garage (**FIG. C**). This can be done with heavy wire such as our #.041 Safety Wire (#43045). Large heavy items should be supported on bricks or stone blocks covered with aluminum foil to prevent static attraction of dust onto your piece. Added stability will then be provided by securing the item to your wire “clothesline” (**FIG. D**).

USING THE INFRARED THERMOMETER

The infrared thermometer is used to get accurate temperature readings from your object. With these readings, refer to the appropriate chart on page 9 to select cure time (for more details on using these charts refer to “Curing With Your Infrared Light” section). Temperature readings are taken as close to the light-heated area as possible (no more than 3-6” from object). Use common sense when taking temperature readings. Always use heavy leather gloves or welding gloves to protect hands from the heat and never place hands in front of the light (**FIG. E**), when taking readings (to prevent heat burns).

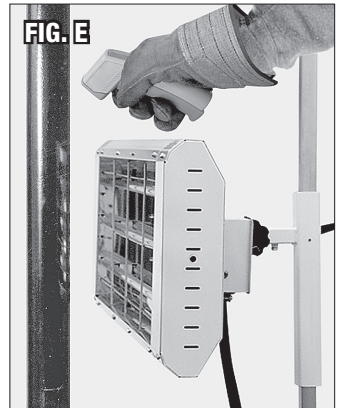
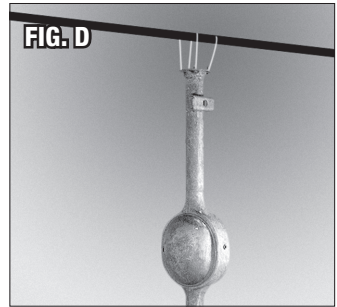
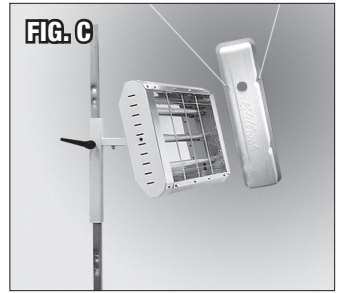

OPERATING THE INFRARED LIGHT

The infrared light is designed to be utilized at a distance of 6-10" from the object and parallel to the piece to be cured (**FIGS F, G**) The light should be periodically positioned and moved around the object as instructed in the curing section. Use an appropriate outlet. Plug the light into a 30 amp, 220 volt circuit, turn on switch, and allow 1-2 minutes for the light to come up to temperature. If you find an area or object demands the light to be FURTHER than 10" adjust the time to meet the temperature in the chart outlined in the curing section (page 9).

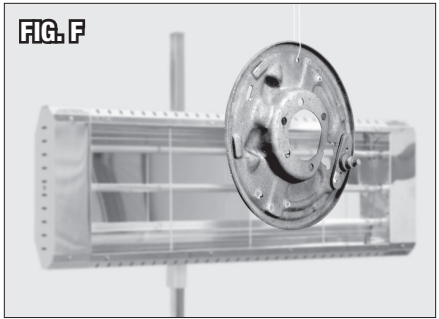

MOVING THE LIGHT

Objects such as a rear axle, driveshaft or any other object that is powder coated on all sides, must be cured from all sides. In order to cure all surfaces of the object, the light must be moved. This is accomplished by moving the light from the bottom of the object to the top (if hung vertically) or from one end to the other (if hung horizontally), allowing the light to bring the surface up to one of the cure temperatures and then held on that spot for the recommended time (**FIGS H, I**). Continually monitor the temperature and adjust your timer as you move the light along. After completing one side, move down the other to completely cure the object.

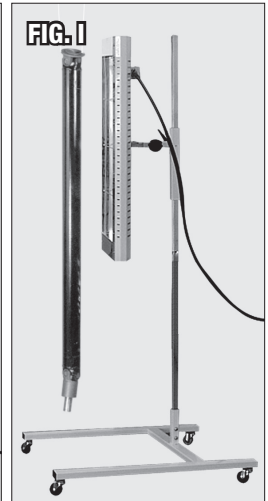
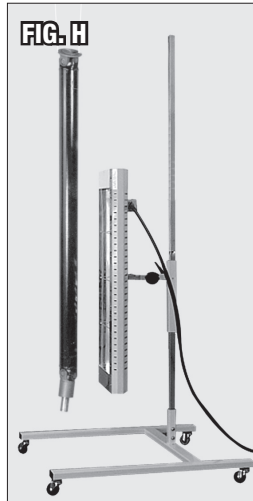

Some thin gauge objects may cure the powder outside the light's focus area. This can be checked and verified with the infrared thermometer. If this is the case, simply move the light through this area into the next, once you have achieved the proper cure time.

GETTING FAMILIAR WITH THE SYSTEM

Read the instructions on pages 9-11 and complete the practice steps below to perfect your technique, before proceeding with your project.

MAINTAINING CONSTANT TEMPERATURES ON THIN GAUGE AND SMALL PARTS:

Thin gauge metal and small pieces are easily cured with your light but must be constantly monitored for temperature and light distance in order to prevent the powder from burning or discoloring.

Strip an old valve cover, timing cover or bend a 12" x 12" piece of thin gauge metal into a "U" shape. Hang this from your wire clothesline and position the light on one end of the piece as described on pages 5-6. Monitor the temperature until you reach 380°F. Adjust the light distance to hold 380°F. Now set your timer and continually monitor the temperature to maintain 380°F (plus or minus 10°) for 15 minutes.

After you have successfully held the 380°F. for 15 minutes move the light to the next section (the width of the light casing) and adjust the light distance if needed, to hold 380°F. for an additional 15 minutes. Continue this technique of maintaining the temperature, setting your timer and moving to the next area until the entire piece has been cured.

NOTE: You will notice the temperature may rise above 380°F. directly in front of the light in as little as 4-5 minutes, simply move the light back a few inches to maintain 380°F. Thin gauge metal and small pieces are easily cured with your light but must be constantly monitored for temperature and light distance. On a valve cover with the light positioned at one end you will begin to flow out the powder in 5 minutes and will have to move the light a distance of about 5"-6" from the piece. At this distance you will notice the temperature will level out. If it falls below your original starting temperature simply refer to the correct chart for the time at this new temperature and set your timer. After some practice you will be able to move the light closer to obtain a higher temperature to speed the curing time.

MAINTAINING CONSTANT TEMPERATURES ON LARGE CASTINGS, TRANSMISSION HOUSINGS, REAR HOUSINGS, ETC:

Large stampings such as alternator brackets, radiator supports along with heavy castings, such as rear housings will hold constant temperatures easier than sheet metal. These are the items the light was designed for. You will be able to quickly determine the correct light distance, temperature and cure time for the color of your choice.

Strip an old brake drum, wheel or piece of shop equipment such as a bench vise. Support the piece as described on page 5. Start with the light at 6-8" and monitor temperature after 5 minutes. These heavy pieces will require a longer time to come up to temperature, due to the piece absorbing the heat. A brake drum will require about 8 minutes to reach 370°F. After you reach a temperature in the middle range of the cure chart, for your color choice, you will find the light may not need to be moved further from the piece but only into the next area.

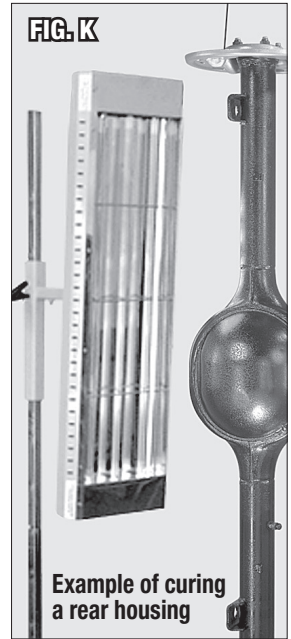
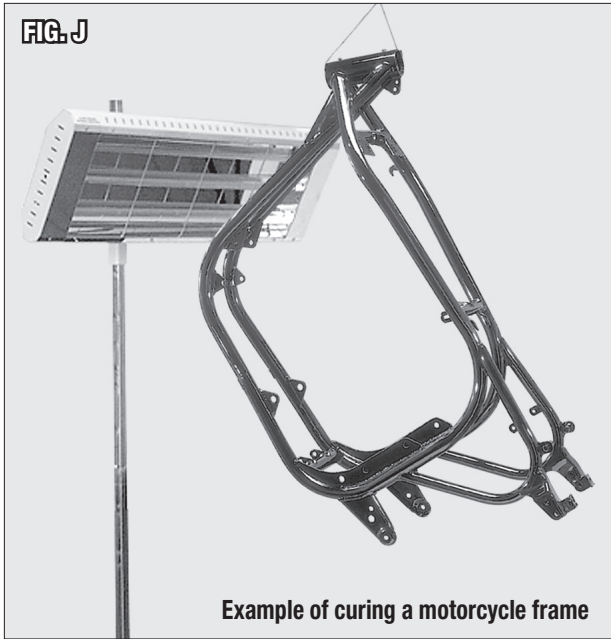

SELECTING TEMPERATURE & CURE TIME

The key to successful curing is close monitoring of the temperature. The included infrared thermometer will give you this precision temperature reading while the adjustable stand will give you the freedom to move the light around the object for total curing. Follow the charts below for accurate curing of the Eastwood powders.

If you powder coat with Eastwood Translucent and Specialty powders you must maintain a minimum of 365°F. for 25 minutes as per the chart below. For Solid and Clear colors a minimum of 320°F. for 15 minutes must be held. Curing at higher temperatures on the charts is acceptable as long as the temperature is held for the specified time.

CURE CHART FOR TRANSLUCENT AND SPECIALTY COLORS

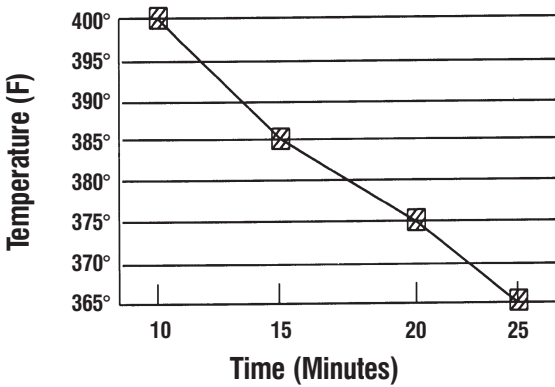

CURE CHART FOR SOLID AND CLEAR COLORS

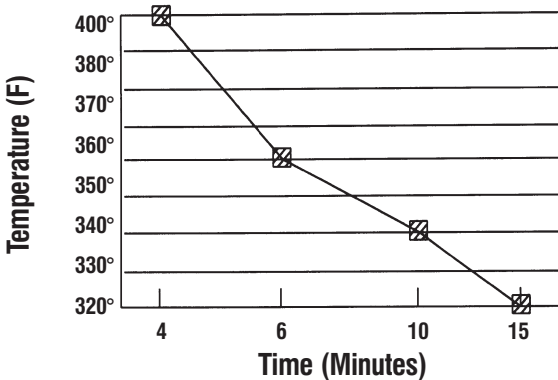

CURING WITH THE INFRARED LIGHT

NOTE: Practice maintaining cure temperatures as outlined on page 7-9 before curing powder as detailed below.

1. The objective is to maintain a constant temperature for a sufficient length of time in order to properly cure the powder you are using. Refer to the appropriate cure chart on page 9 to determine the range of cure temperatures recommended for the powder you are using (365° – 400°F. for translucent and specialty colors and 320° – 400°F. for standard solid colors and clears). The difference in cure time is due to the chemical make up of the powders, so be sure to use the correct chart for the powder you're using. For example, the Translucent and Specialty colors require a cure time of 17 minutes at 380°F, while the Solid and Clears only require 5 minutes at 380°F. An inexpensive cooking timer is recommended to monitor curing times.

NOTE: It is best to select a cure temperature in the middle of the temperature range indicated on the cure charts because if you go over 400°F. you risk burning the powder particularly for metal items that heat up quickly such as sheet metal and small items. Also some colors such as the solid reds and whites are more prone to burn at temperatures over 400°F. Once you have developed more experience with the system you can try working closer to the upper range of cure temperatures in order to speed your work.

NOTE: If your temperature drops by (-) 10° or increases as high as (+) 10° degrees over your target temperature, this is O.K. as the Eastwood powders will still properly cure. The Eastwood powders have some resistance to over bake as long as you do not exceed the 400° mark for extended periods of time.

2. Before powder is applied, position the light 6"-8" from the piece and note the temperature on the part after 3-5 minutes. If the temperature is over 400°F. at this point, move the light further from the part by an inch or two.

NOTE: Do not operate the light closer than 5". This will cause the temperature to rise very quickly and burn the powder. For thin gauge metal or small parts such as a master cylinder lid, valve cover or small brackets will heat up very quickly. Therefore, the temperature must be constantly monitored and the light distance corrected to maintain the temperature below 400°F. For large parts such as rear housings, transmission case or driveshafts, the piece will heat up slowly and maintain a fairly constant temperature due to the heat absorption. You will still have to monitor the temperature regularly but may not have to vary the light distance.

3. Take another reading after an additional 3 minutes. Repeat your temperature readings every three minutes and adjust the light distance if necessary from the part until you have achieved a consistent temperature reading within the appropriate temperature range for your powder. Make a note of the distance and temperature and determine the cure time required from the appropriate table. This information will be your starting point when you actually begin to cure the powder.

1. Remove the light, allow the piece to cool and then apply the powder according to the directions supplied with the Powder Coating gun.
2. Position the light at one end of the piece at the distance you have previously determined.
NOTE: Always cure parts starting from the bottom up and if curing powder on the other side, begin at the top and work your way back down to the bottom. For parts oriented from side to side, start from one end and if curing the backside, work your way back on the other side to the starting point. When curing tubular objects such as motorcycle frames, driveshafts, etc., even though all sides of the tube may melt and flow out at the same time, you should still cure both sides for the required amount of time. Start the light at the bottom of the piece and follow the correct cure chart while working up one side. Then move the light to the other side and work your way down to the starting point.
3. Once the heated area is up to temperature, set your timer according to the chart. Check the temperature every three minutes or so to make sure the temperature is stable and adjust the light distance or adjust the cure time where appropriate.
4. When it's time to move the light, simply move it the width of the lamp case into the immediate adjacent area. Repeat the temperature monitoring and adjust light distance and/or cure time where necessary.
NOTE: You will notice the powder melting, or flowing out, outside the lights focused area. This is normal and you can verify cures by simply taking temperature readings in front of the light and also outside the focused area. If you notice the temperature outside the area is adequate for a proper cure, when its time to move the light, simply pass through that area into the next adjacent area.
5. After you have completed your test piece check the cure by the MEK wipe test as described on the following page.

TESTING FOR A COMPLETE CURE

This test is done by taking a clean, soft rag with a little MEK (methyl ethyl ketone) on it and lightly rubbing an inconspicuous spot 2 or 3 times (FIG L). If you notice the color easily transfers to the rag, you have an incomplete cure. Proceed to the troubleshooting chart below for proper curing.



TROUBLESHOOTING

PROBLEM	CAUSE	CORRECTION
Failed MEK Test	Incomplete Cure	Use the correct chart for the powder you are using. Try recurring the piece using the correct chart, temperature and distance. If, after the second cure the piece still fails the MEK (methyl ethyl ketone) test, you must strip the coating using automotive paint stripper or abrasive blasting with plastic media.
Burnt Area	Light Too Close to Piece	Keep light a minimum of 5" from piece, or further to maintain temperatures no higher than 400°F.
	Temperature not Closely Monitored	Continuously monitor temperature as described in the "Curing With Your Infrared Light" section on page 9. You may have to increase the distance from the light to the piece to keep temperature from going over 400°F. NOTE: Master cylinder lids and air cleaners will require the light to be about 6" from the pieces.

ELEMENT REPLACEMENT

With proper care, the elements are designed to provide long-term, dependable service for approx. 5000 hours of service. By following these instructions you can help insure that you receive the maximum possible life from your infrared curing system. 36" replacement element is item #10680B.

⚠ DANGER

- **Unplug Lamp before changing bulbs or performing any maintenance.**
- **Wear eye protection and gloves when changing bulbs.**
- **Never touch lamps when they are on or until they are fully cooled.**

REMOVAL

1. Unplug unit and remove from stand at the cross arm leaving the cross arm attached to the stand.
2. Place your infrared light unit on a solid object such as a workbench or table.
3. The light should be positioned on its back with the elements up and supported with blocks so the unit will not shift while you are working on it.
4. Use a medium width, flat blade screwdriver, and remove the four screws that hold the two end covers and grill in place (**FIG M**).
5. Remove both end covers and grill to expose the elements.
6. Using an 11/32" end wrench gently loosen the outside mounting/locking nuts at both ends of the element (**FIG N**).
7. With your fingers, grasp the element at the ceramic ends and gently pull upwards (**FIG O**).

NOTE: The element mounts may be slightly spring loaded. Once clear of the contacts, tip one end of the element up to clear the top edge of the unit then remove the element from the housing. **IMPORTANT:** Use caution not to break the quartz glass, which could create a sharp edge that could cut you.

8. Dispose of used Element by wrapping it in the shipping material that your new replacement element was shipped in. Then dispose with common trash.

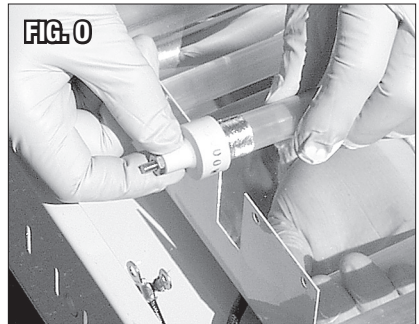
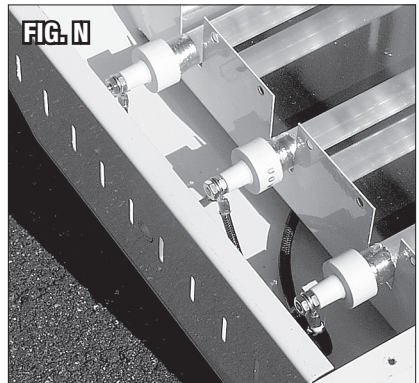

INSTALLATION OF NEW ELEMENT

1. Carefully unpack your replacement element. Inspect for damage. Save packaging material for use in disposal of your old element.
2. Using your 11/32" end wrench, GENTLY loosen the exterior or outside retaining nuts on the threaded studs on both ends of the element. DO NOT ALLOW THE MOUNTING STUD TO TURN.
3. Using your 11/32" end wrench carefully and GENTLY snug the inside lock nut next to the ceramic end pieces. DO NOT ALLOW THE MOUNTING STUD TO TURN (FIG P).
4. Holding the element by the ceramic ends, tip in one side of the element into the unit's housing adjusting to the side to allow clearance for the other side to enter the housing. Avoid touching the quartz glass directly (FIG Q).

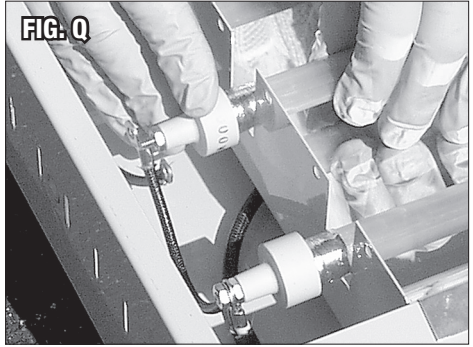
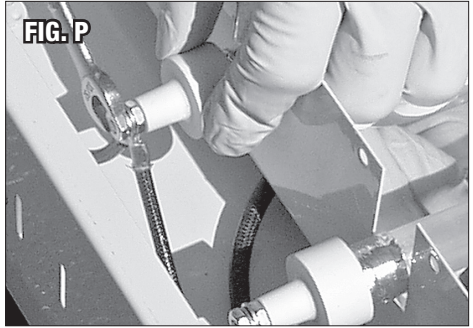

5. Once inside the housing, mount the element on the element holder and gently tighten the outside retaining nuts.
NOTE: The mount may be slightly spring loaded. If so, GENTLY spread mounts with fingers to allow mounting studs to lower fully into the proper mounting position. DO NOT FORCE THE ELEMENT INTO POSITION as this may break the quartz glass, ceramic end caps, studs or mounting bracket ceramic insulators.
6. Once the element is in the proper position, use your 11/32" end wrench to GENTLY snug up the mounting lock nuts.
7. Re-mount the grill and end caps to the unit's housing. Remember the end caps are held on by sheet metal screws. DO NOT over tighten.
8. Re-mount unit to the cross arm and stand.
9. Clean elements with a soft clean rag and alcohol to remove finger prints or contaminants.
10. Plug unit into an appropriate power supply and test for proper operation.

ADDITIONAL ELEMENT MAINTENANCE AND PERFORMANCE INFORMATION

⚠ DANGER

- DO NOT touch elements before they are fully cooled.
- Unplug Lamp before performing any maintenance.

- Elements should be cleaned with alcohol to remove human or other oils.
- Element mounting points should be checked for tightness frequently.

If you have any questions about the use of this product, please contact

The Eastwood Technical Assistance Service Department: 800.343.9353 >> email: techelp@eastwood.com

PDF version of this manual is available at eastwood.com

The Eastwood Company 263 Shoemaker Road, Pottstown, PA 19464, USA

800.343.9353 eastwood.com